

EVA 5

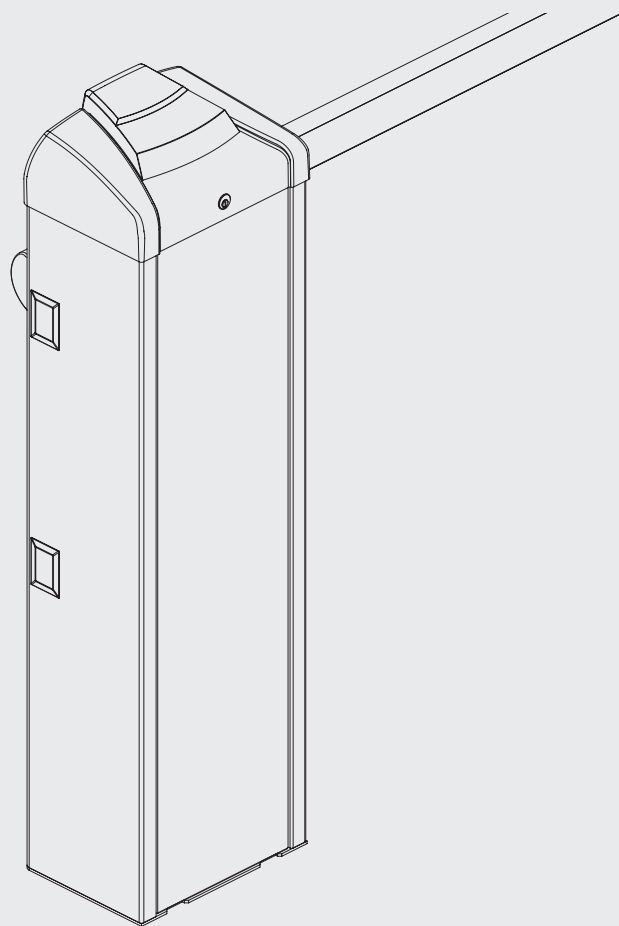

BENINCA[®]
TECHNOLOGY TO OPEN

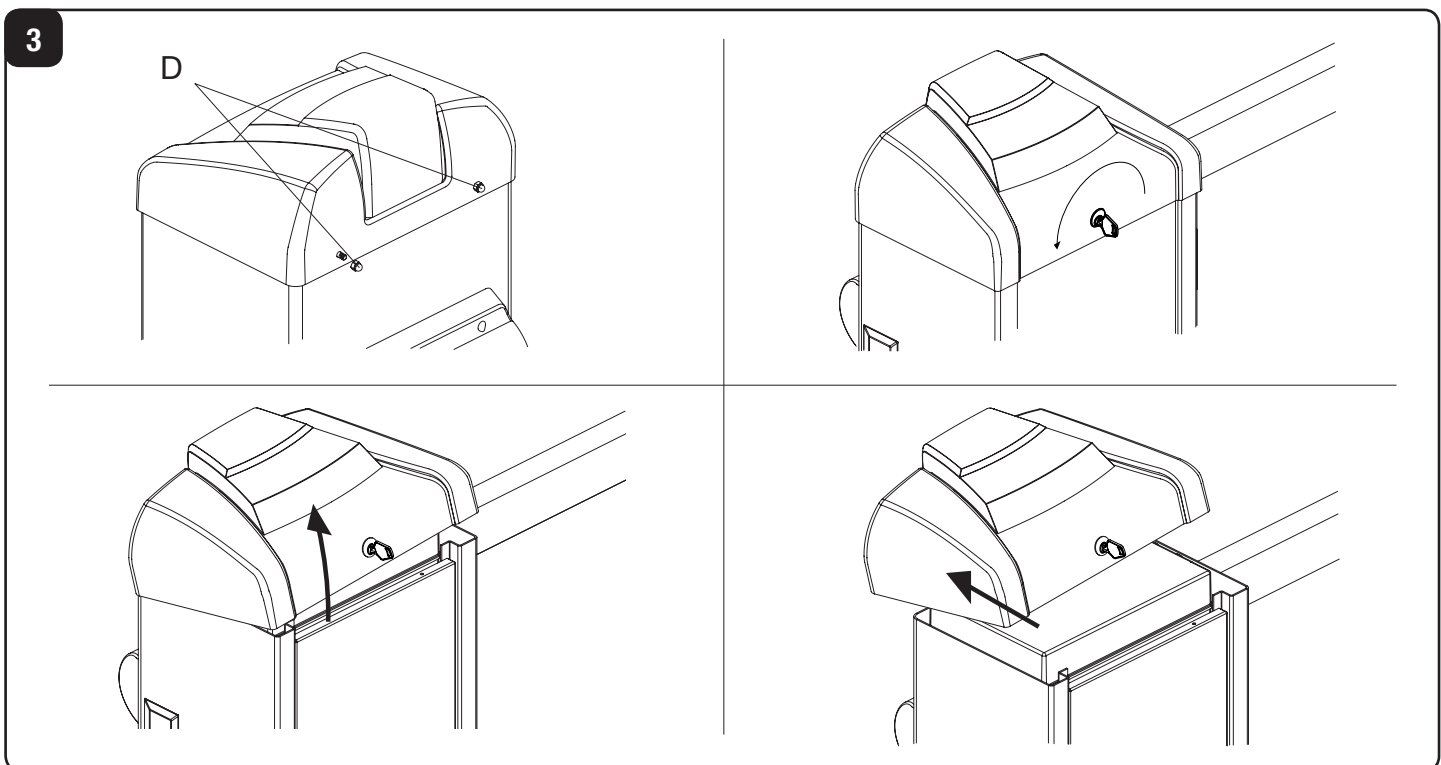

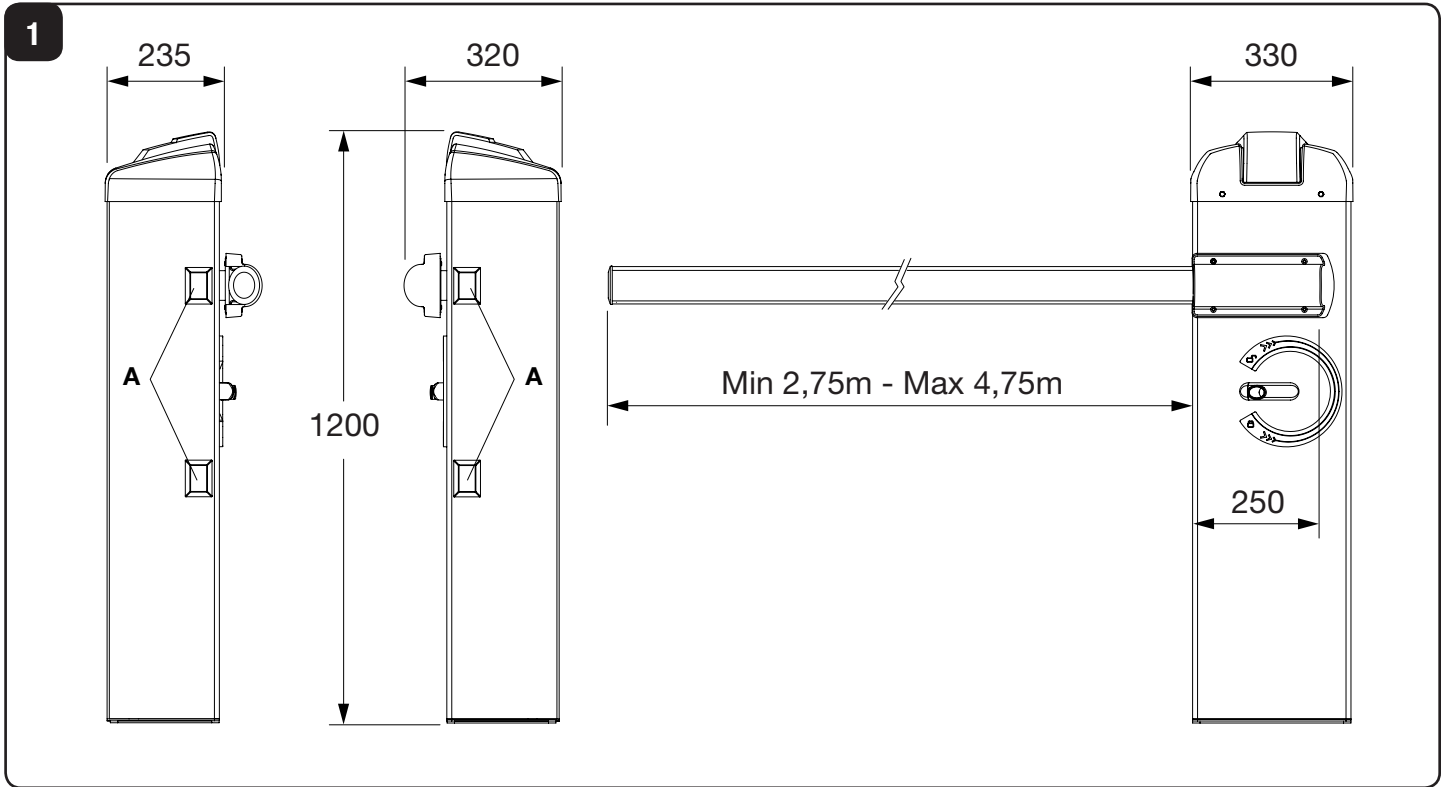

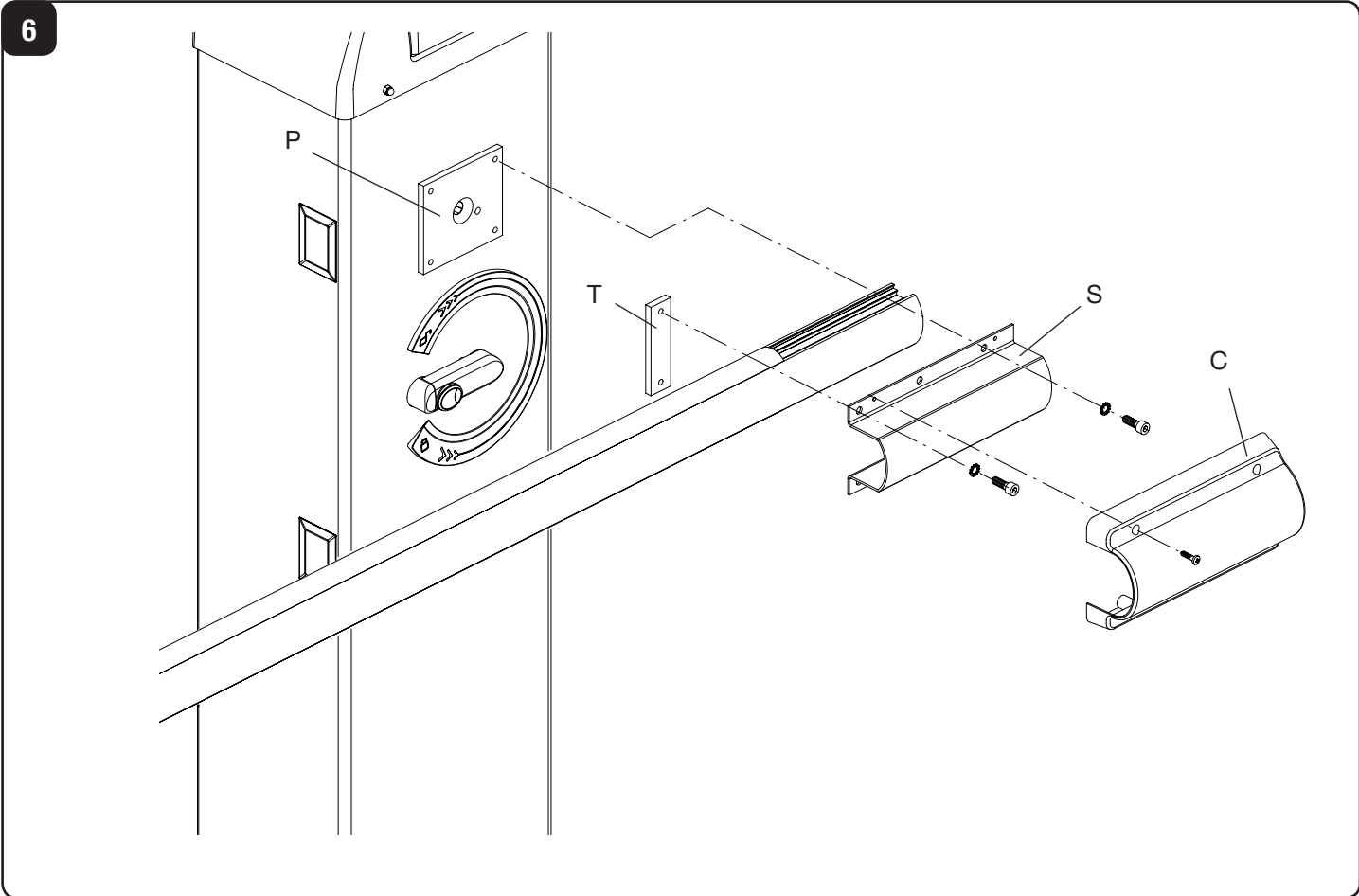
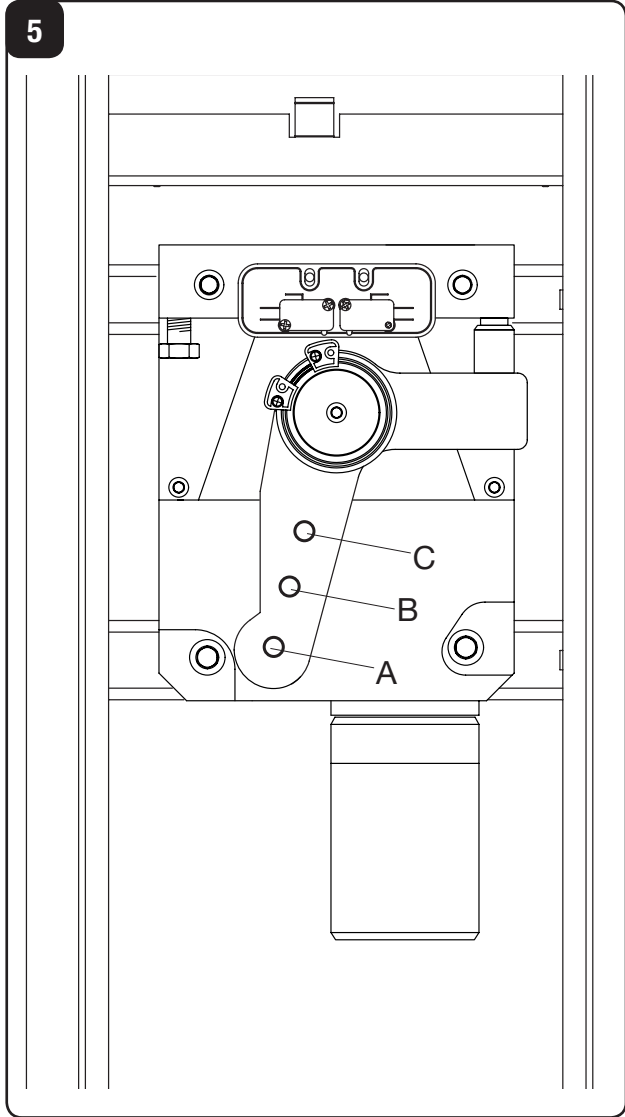
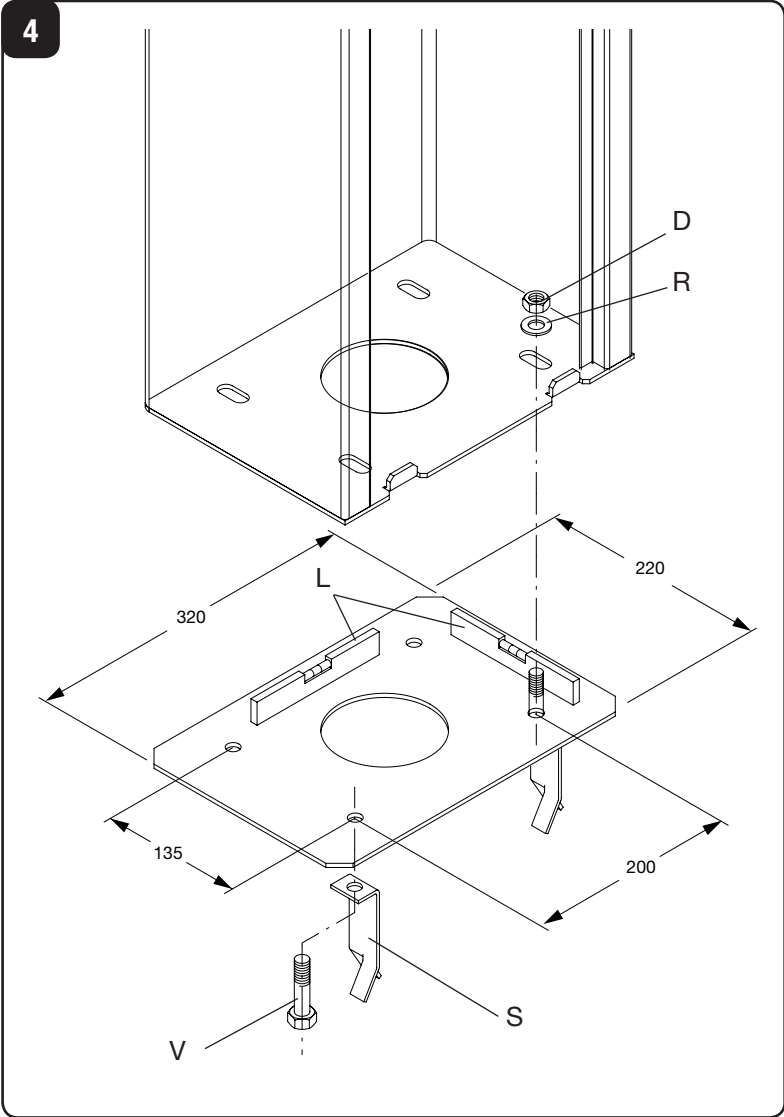

7

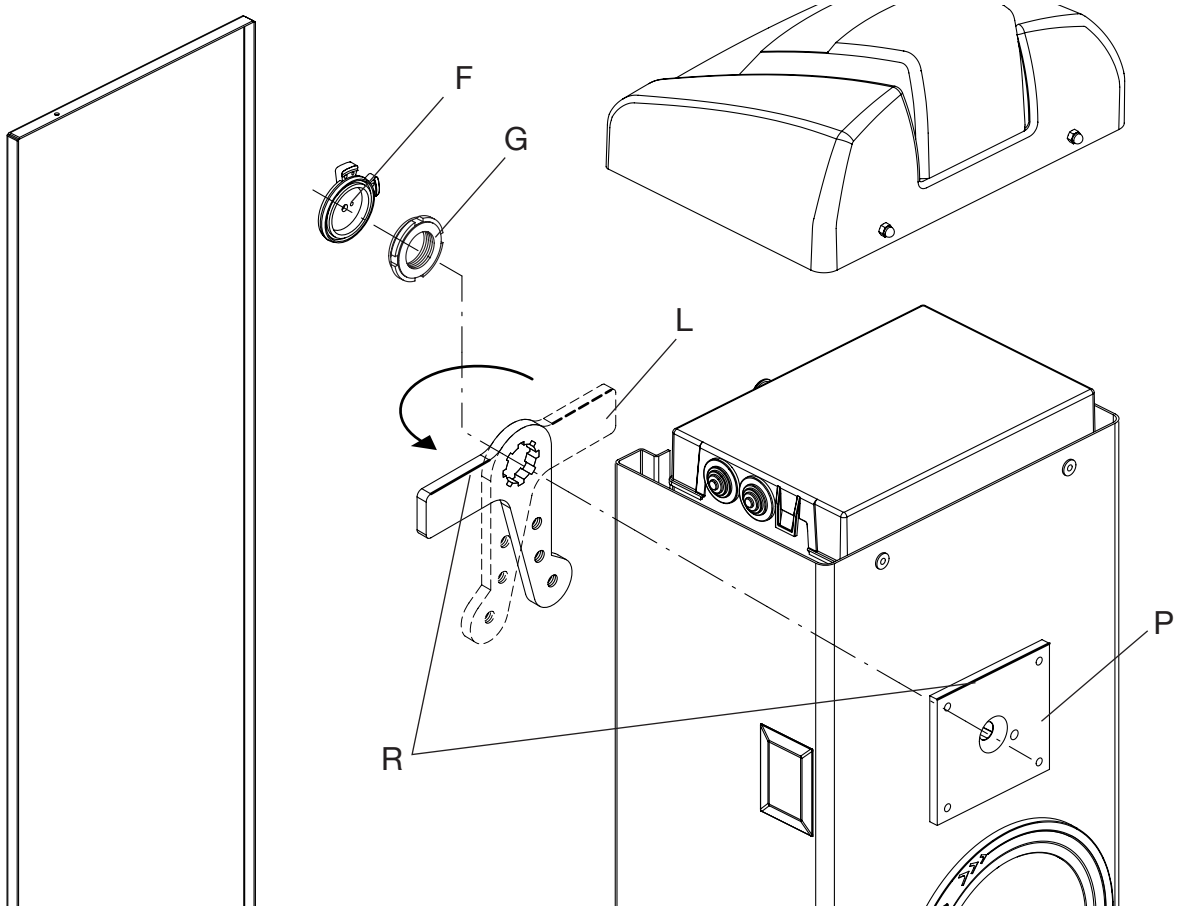

8

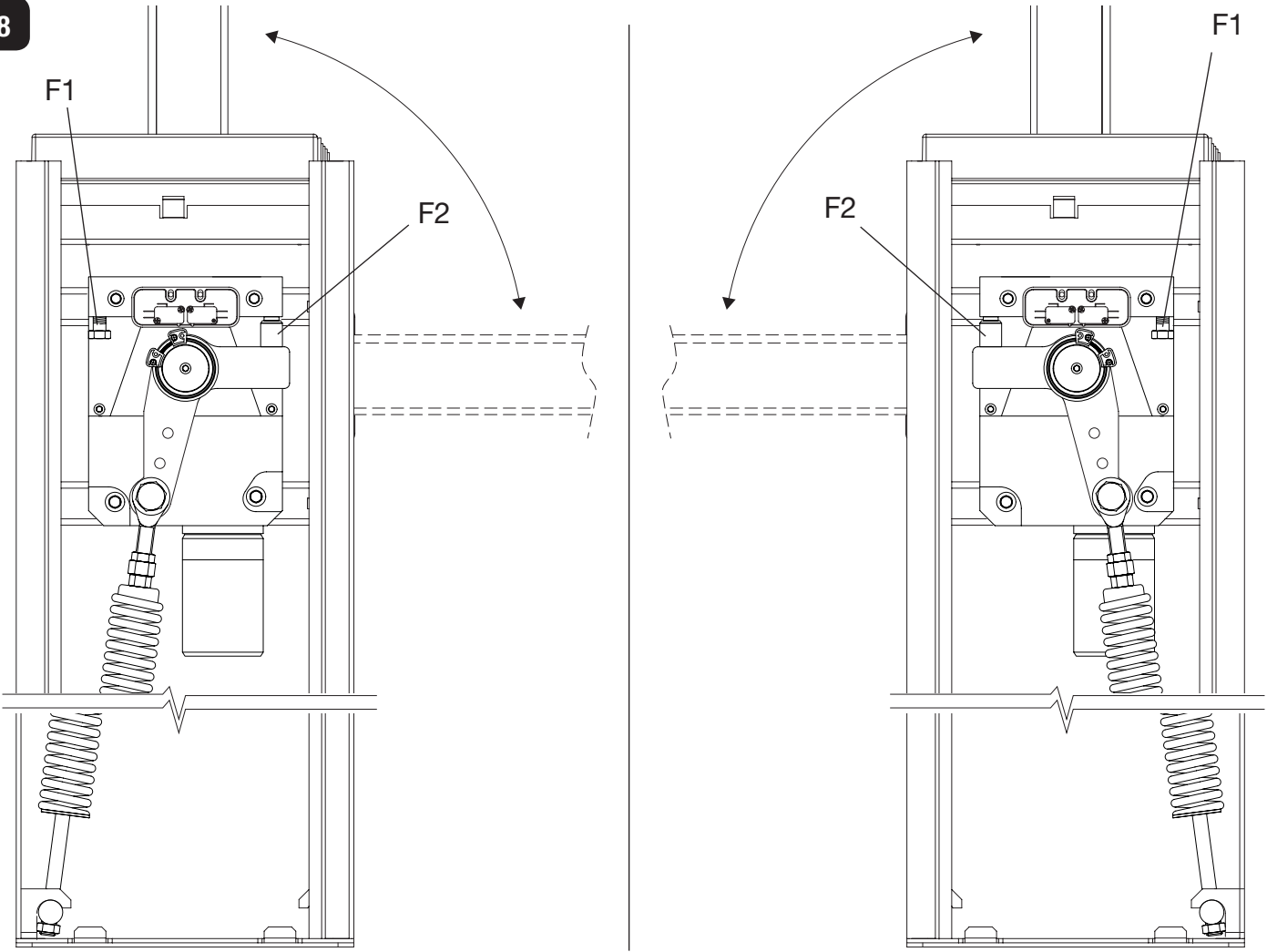

9

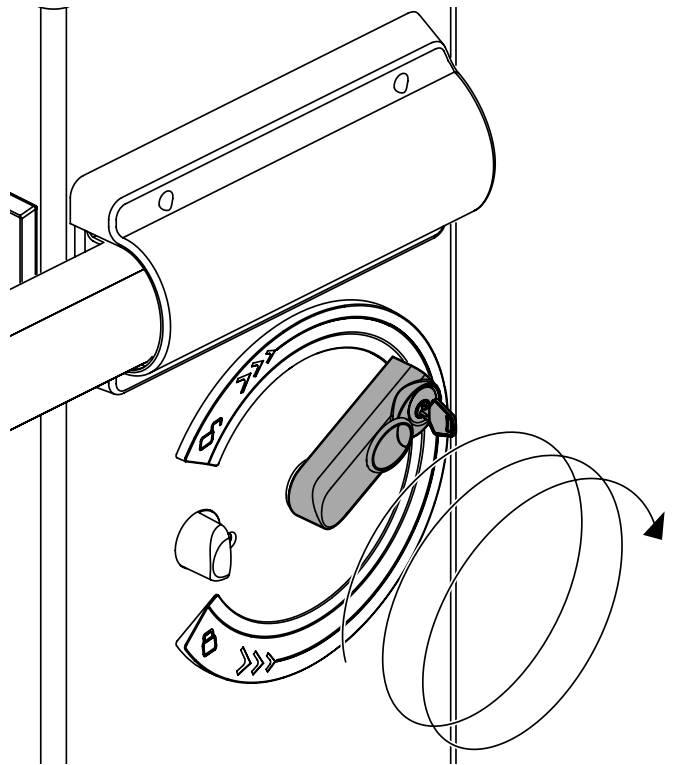
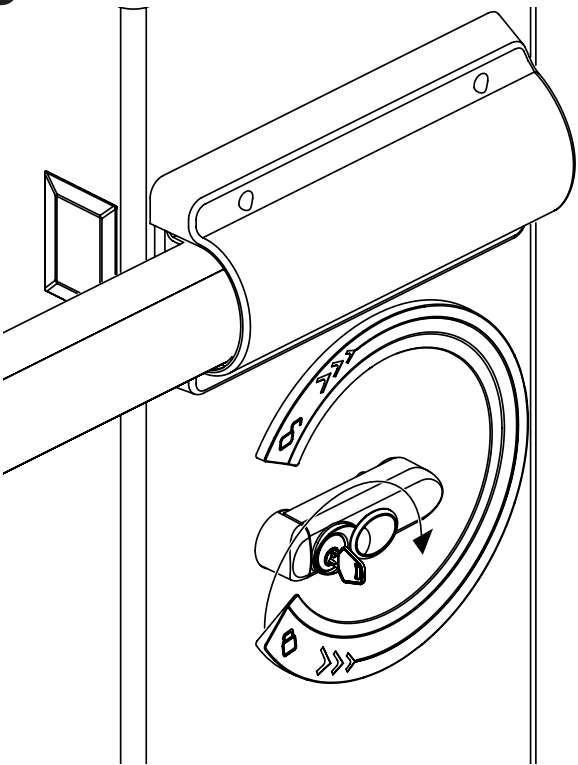

10

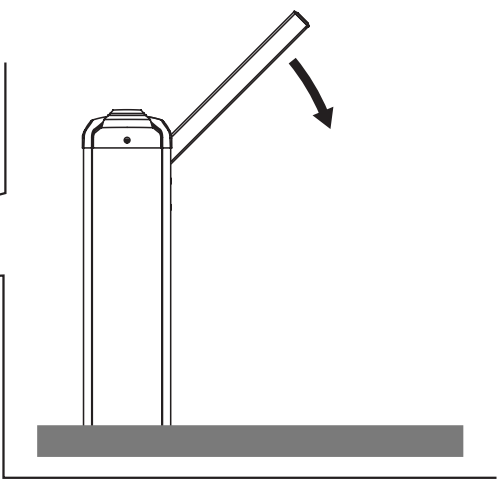
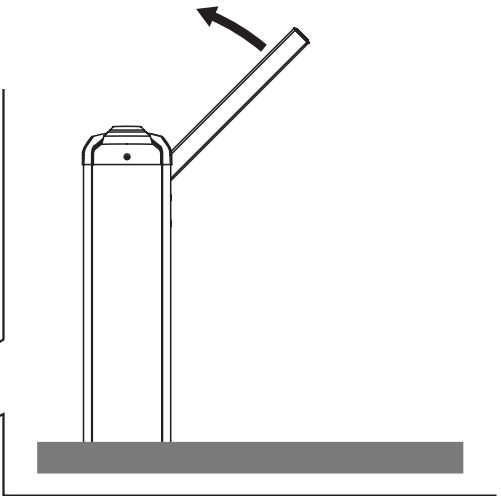
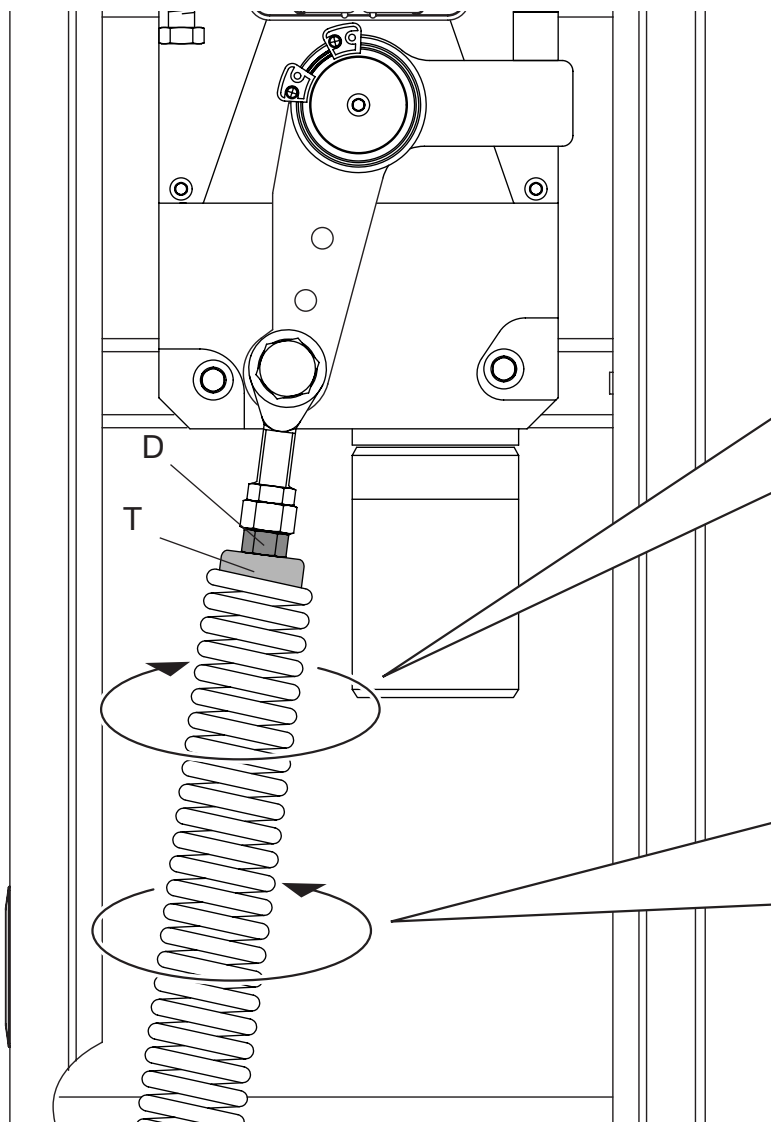

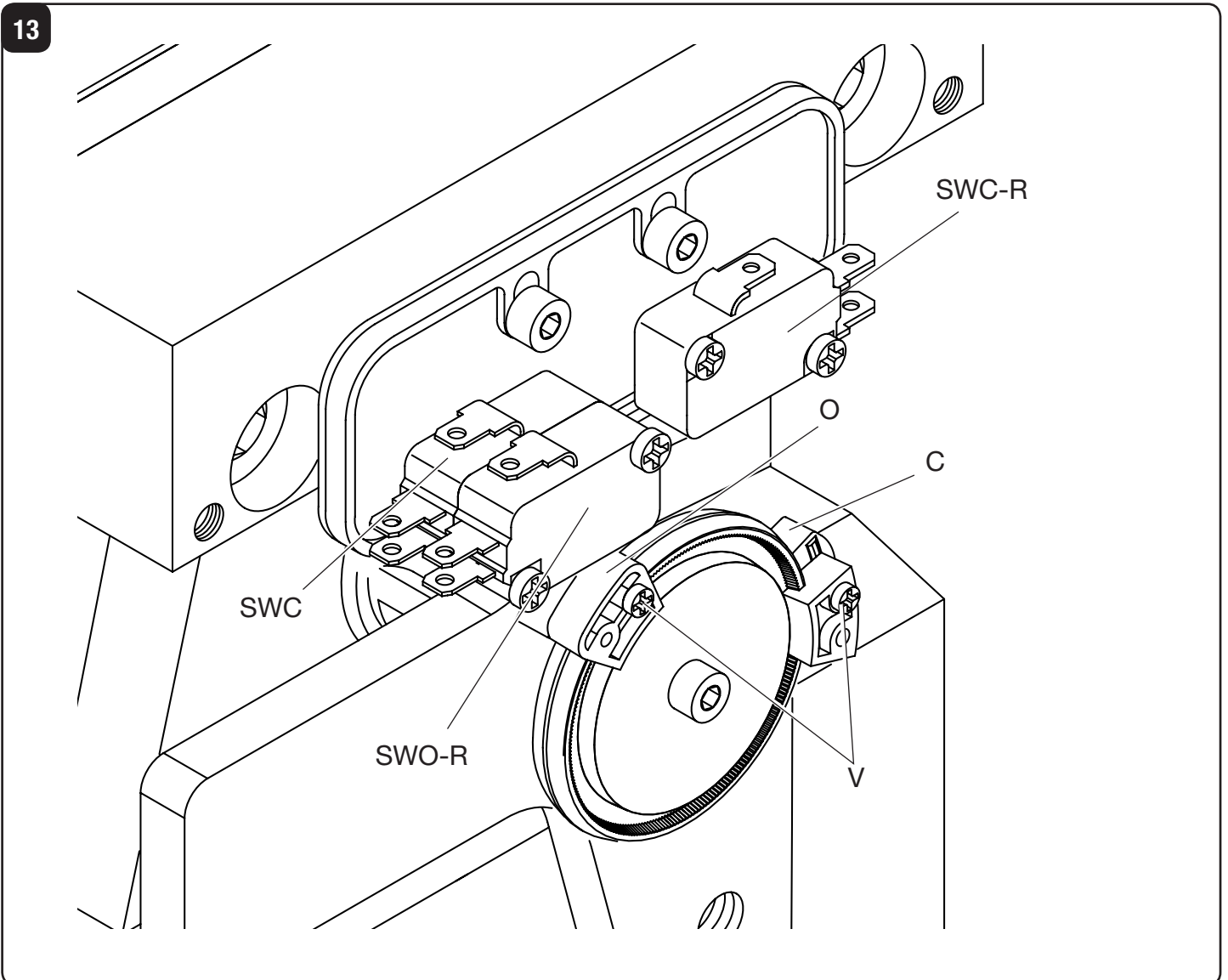
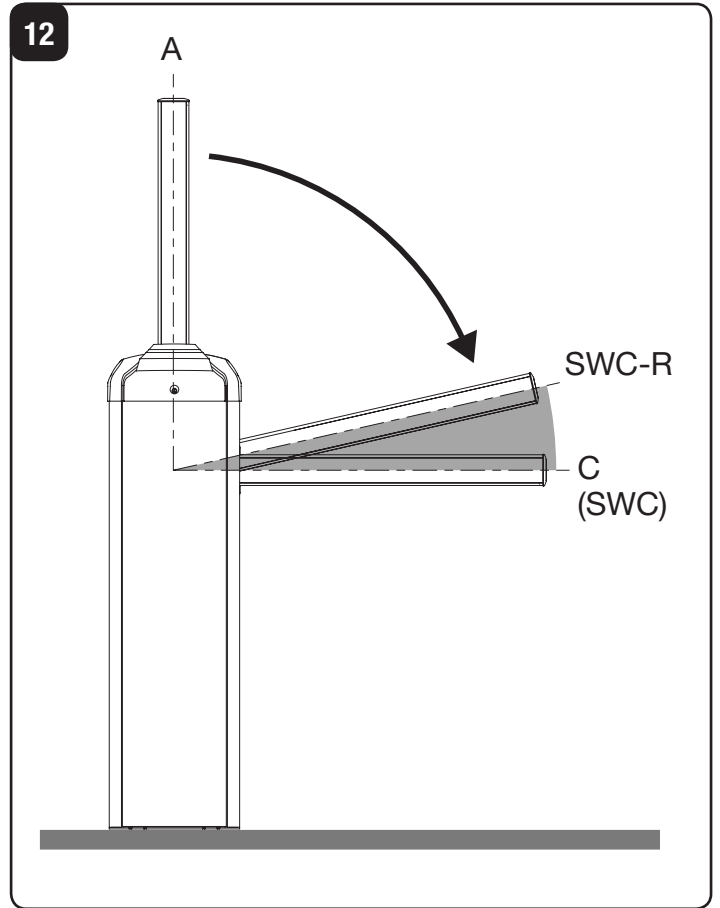
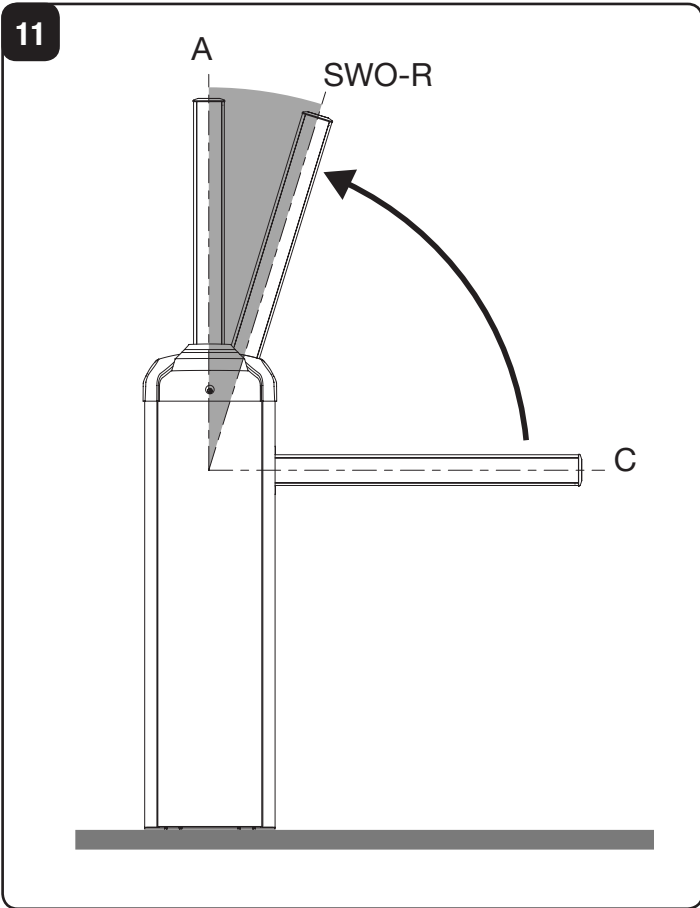

14

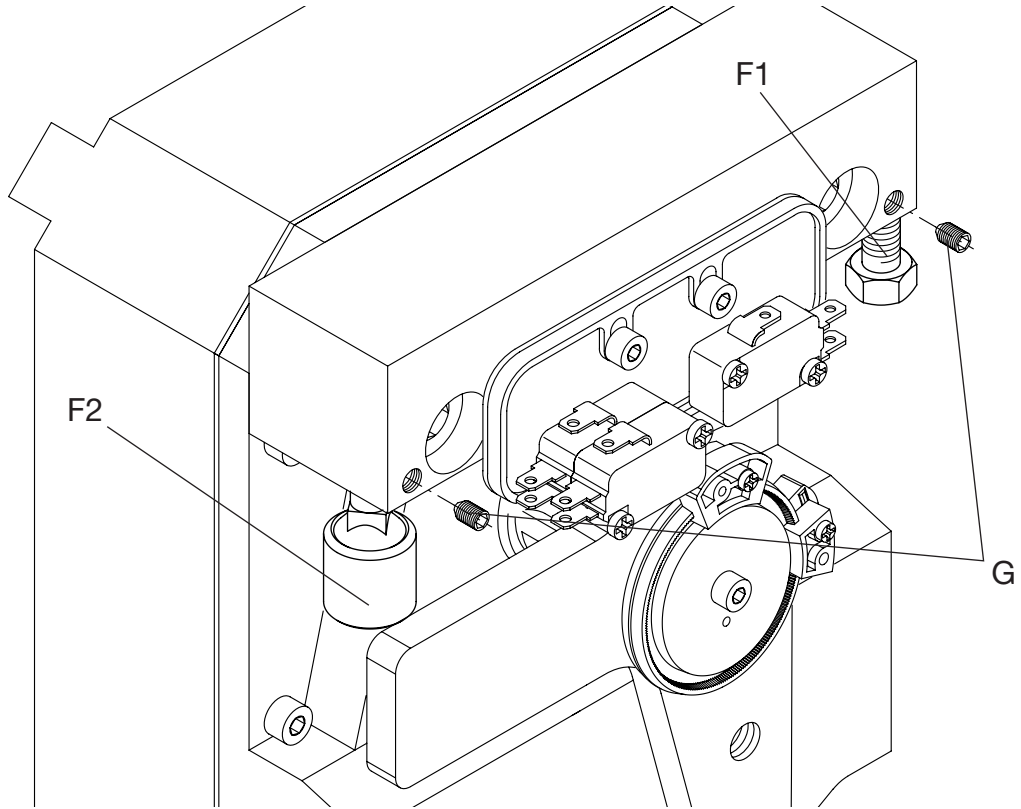

15

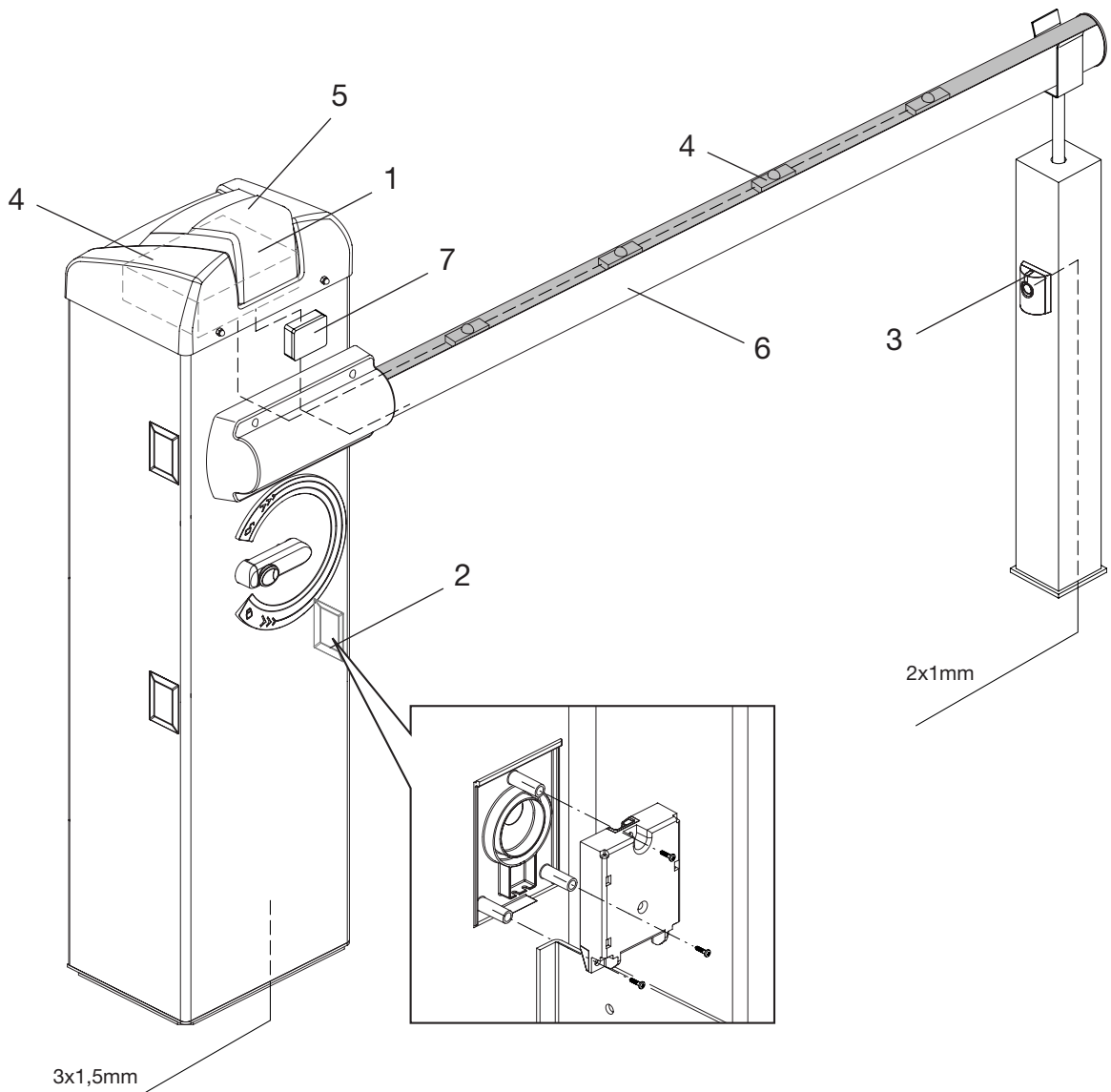

EC Declaration of Conformity regarding machines (Directive 89/392 CE, Annex II B) - No servicing

Manufacturer: **Automatismi Benincà SpA.**
Address: Via Capitello, 45 - 36066 Sandrigo (VI) - Italia

We herewith declare that: the operator for road gates, **EVA 5** model.

- is intended to be incorporated into a machine or assembled together with other devices to form a machine in compliance with the EC Directive 98/37, as amended;
- therefore, is not in every respect complying with this Directive;
- is complying with provisions set forth by the following other EC Directive:
EC Low voltage Directive (73/23/EEC, 93/68/EEC).
EC Directive of Electromagnetic Compatibility (89/336/EEC, 93/68/EEC)

Moreover, we herewith declare that the system shall not be put into service until the machine in which the same will be incorporated or of which it will become a component, is acknowledged compliant with the EC Directive 98/73 and applicable national legislation and a related declaration of conformity is drawn up. In other words, no servicing shall be carried out until the system under this declaration does not form one single final machine with other components.

Benincà Luigi, Legal responsible.
Sandrigo, 08/04/2008.

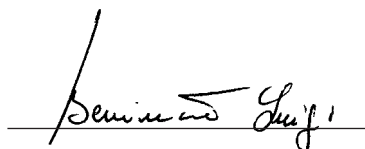

WARNING

The product shall not be used for purposes or in ways other than those for which the product is intended for and as described in this manual. Incorrect uses can damage the product and cause injuries and damages.

The company shall not be deemed responsible for the non-compliance with a good manufacture technique of gates as well as for any deformation, which might occur during use.

Keep this manual for further use.

Qualified personnel, in compliance with regulations in force, shall install the system.

Packaging must be kept out of reach of children, as it can be hazardous. For disposal, packaging must be divided the various types of waste (e.g. carton board, polystyrene) in compliance with regulations in force.

The installer must supply all information on the automatic, manual and emergency operation of the automatic system and supply the end user with instructions for use.



An omnipolar switch/section switch with remote contact opening equal to, or higher than 3mm must be provided on the power supply mains.. Make sure that before wiring an adequate differential switch and an overcurrent protection is provided.

Pursuant to safety regulations in force, some types of installation require that the gate connection be earthed.

During installation, maintenance and repair, cut off power supply before accessing to live parts.

Descriptions and figures in this manual are not binding. While leaving the essential characteristics of the product unchanged, the manufacturer reserves the right to modify the same under the technical, design or commercial point of view without necessarily update this manual.

INTRODUCTION

Thank you for choosing our **EVA 5** road gate.

All items included in Benincà's wide product range stem from twenty year of our experience in the sector of automatic systems, always striving to find new materials and advanced technologies.

For this reason, nowadays we are able to offer you extremely reliable products that, thanks to their power, efficiency and long-lasting features, entirely meet the end user's requirements.

All our products are covered by a guarantee.

Furthermore, an R.C. insurance policy signed with a primary insurance company, covers any injuries or damages caused by manufacturing faults.

GENERAL INFORMATION

Of rugged construction, with an innovative and pleasant design, the road barriers EVA are suited for intensive use thanks to their 24VDC motor. This system is very easy to install and adjust.

Equipped with an easy-to-use manual release, the barrier is preset to assemble buffer batteries to allow its operation in the event of power failure.

The arm in paint aluminium allows for the housing of any accessories, as well as forewarning and safety devices. In the event the arm hits an obstacle, an amperometric sensor causes the movement reversion immediately.

The control unit is placed on the upper side of the barrier to facilitate wire connections.

SPECIFICATION	EVA 5
Power supply	230Vac 50Hz
Motor power supply	24Vdc
Power drawn	120 W
Current absorption	4,6 A
Torque	130 Nm
Jogging	Intensive use
Protection class	IP54
Operating temperature	-20°C / +70°C
Noise	<70 dB
Lubrication	Agip GR MU EP/2
Weight	55kg

OPENING SPEED		
Motor power supply	Opening time (s)	Closing time (s)
26 Vdc	3	4
23 Vdc	4	5
18 Vdc	5	6

The opening time of the road barrier changes according to the supply voltage selected on the transformer of the control unit. Times shown include braking.

DIMENSIONS

FIG.1

Overall dimensions are expressed in mm.

The road barrier length ranges from 3m minimum to 5m maximum.

As about 25cm are required to fix a road barrier, a useful opening of passage, ranging from 2.75m to 4.75, will be

available, as shown in Fig.1

Optional accessories can be fitted onto the barrier (photo-cells, selector, etc.). For assembly, apply the special covers supplied (Rif. A).

RIGHT/LEFT-HAND OPENING OF THE BARRIER

FIG.2

The EVA 5 road barrier is available in both right (EVA5-DX) and left (EVA5-SX) models.

With reference to Fig.2, a right-hand opening road barrier is a system which, seen from the door side, closes the right-hand side of the passage. The left-hand opening is in the opposite way.

As the opening side can be changed at any moment, it is advisable to buy a type of road barrier which allows the easiest and rapid installation.

OPENING

FIG.3

The access to the electric and mechanical components of the road barrier is protected by a lock with customized key. Proceed as follows:

- 1 loosen the two nuts D
- 2 introduce the key in the lock on the side of the door and turn it anti-clockwise
- 3 lift the front cover
- 4 remove the cover

By removing the front door it is now possible to reach both the control unit, that is placed under the cover, and the mechanical parts of the road barrier.

INSTALLATION OF THE FOUNDATION PLATE

FIG.4

After preparing the cable laying (mains power supply, accessories, etc.), place the foundation plate keeping to dimensions indicated.

Brackets to be cemented are supplied with the system (ref. S). The brackets must be fitted to the foundation plate by means of 4 screws M12x50 (ref. V).

Check that the foundation plate is perfectly flat (ref. L), then fix the road barrier by means of nuts D and corresponding washers R.

POSITIONING OF THE SPRING AND ACCESSORIES

FIG.5

According to the length of the beam and the type of accessories installed, before tensioning the spring, the correct point to hook the spring to the lever must be selected.

The correct hooking point ("A", "B" and "C"), must be selected by taking account of table 1, according to the beam length and the type of accessories to be installed.

HOW TO FIX THE BEAM

FIG.6

Any accessories for the beam (protection edges, lights, pneumatic safety edges, rack, etc.) are installed before fitting the beam. See relevant instructions.

Fit the beam to plate P by using bracket S and both the 6 screws with the corresponding washers, and plate T.

Apply the removable plastic cover C.

TAB.1	EVA 5				
	Bar length (m)				
Accessories for use	3	3,5	4	4,5	5
EVA5.A	C	C	B	B	A
EVA5.A + VE.RAST	C	B	B	A	A
EVA5.A + VE.AM	C	C	B	B	A
EVA5.A + VE.RAST + VE.AM	C	B	B	A	A
EVA5.A + SC.RES	C	B	B	A	A
EVA5.A + SC.RES + VE.AM	C	B	B	A	A

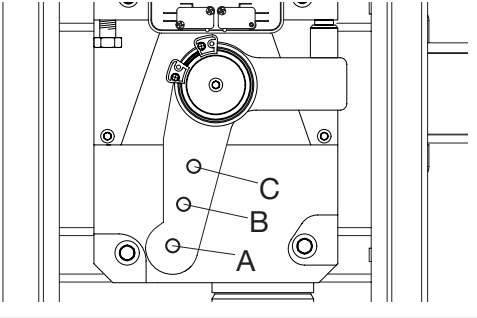
<p>Key</p> <p>EVA5.A Shank with rubber and upper profile.</p> <p>VE.RAST Aluminium skirt.</p> <p>VE.AM Mobile support for bar.</p> <p>SC.RES Sensitive resistive edge (complying with annexe 4 of the Machines Directive).</p> <p>Attention: The installation of the VE.RAST interferes with the use of the SC.RES and vice versa. The installation of the EVA.L lights kit does not influence the balancing of the bar</p>	
---	---

PREPARATION OF A RIGHT-HAND OR LEFT-HAND ROAD BARRIER

FIG.7-8

If it is necessary to modify the opening direction of the road barrier from right-hand to left-hand, or viceversa, proceed as follows:

- totally unload the spring and unhook it from the anchoring lever "L"
- remove the limit switch disc (fig.7 ref F)
- loosen the lock ring nut (fig.7 ref G)
- remove the spring anchoring lever (fig.7 ref L) and place it opposite the previous position
- check alignment (fig.7 ref R) between the fitting plate "P" and the anchoring lever "L"
- taking Fig. 8 as a reference, invert the position of the mechanical stoppers "F1" and "F2". Loosen the corresponding lock grains before loosening the stoppers (see paragraph ADJUSTMENT OF MECHANICAL STOPPERS)
- hook the spring in the new position. Fig. 9 shows the differences between a right-hand road barrier and a left-hand one.
- **in the control unit, invert the wires of motor, as well as SWC limit switch (closing limit switch) and SWC-R limit switch (closure braking limit switch).**

EMERGENCY MANUAL OPERATION

FIG.9

Should a power failure occur or in the event of faults in the system, the beam can be released and moved by hand:

- Introduce the customized key in the release lever and turn it clockwise.
- Turn the release lever clockwise until the beam is released and it can be opened and closed by hand.
- To reset the automatic operation, turn the lever anti-clockwise until the beam is released. Reset the initial position.

BALANCING

FIG.10

For a good operation of the road barrier, the beam must be suitably balanced by the spring.

To check the correct balancing, proceed as follows.

- Check that the spring is correctly hooked to the lever (see table 1).
- Mechanically release the road barrier through the release key.
- The road beam, correctly balanced, should remain still in any position:
 - if it tends to open, reduce the spring tension
 - if it tends to close, increase the spring tension
 The spring tension can be adjusted by tightening (anti-clockwise rotation) or loosening (clockwise rotation) the spring by hand. Once the spring tension is adjusted, lock it by moving the nut "D" in contact with cap T.

MOVEMENTS AND OPERATING TIME

During opening as per Fig. 11:

Starting from the closing position "C", the beam starts its opening until it reaches the "SWO-R" point, where the opening limit switch triggers. The opening speed can be adjusted through the control unit.

The beam moves for the remaining space (as shown in Fig.11) at a reduced speed, for a time preset by the control unit. Therefore, the barrier reaches point A, by completing the opening movement.

During closure, as per Fig. 12:

The beam starts moving from the opening point "A" and stops at "SWC-R" point, when the braking limit switch triggers. The closing speed can be preset through the control unit.

After activation of the braking limit switch, the braking cycle starts, ending only when the closing limit switch "C" triggers.

The control unit checks the activation of the "SWC" limit switch and it is able to automatically offset any changes due to different weather conditions, for example.

The braking angle shown in Fig.12 is fixed at around 25°.

Adjustments of the limit switch cams, trimmers and dip-

switches should be carried out by referring to these operating principles.

ADJUSTMENT OF LIMIT SWITCH CAMS

FIG.13

The adjustment of the limit switch cams allow for the following:

Cam O

To advance or delay the starting of braking in the opening phase (Fig.12 - "SWO-R" point).

Cam C

To previously adjust the stop point in the closing phase (Fig.13 - "C" point).

Note: before activating the closing limit switch, the cam C starts braking by triggering the limit switch (Fig.13 - point "SWC-R").

Adjust cams by referring to Fig.13:

- Loosen screw V of cam fitting.
- Move the opening or closing cam in the desired position.
- Tighten the fitting screw V of the cam.

HOW TO ADJUST THE MECHANICAL STOPPERS

FIG.14

After the motor stop, the inertial movement of the beam is blocked thanks to adjustable mechanical stoppers.

After adjusting the opening/closing limit switch cam, move the related closing mechanical stopper against the lever.

The opening mechanical stopper F2 is of the amortized type.

By taking Fig.14 as a reference:

- Loosen the lock grain G
- Tighten/loosen the mechanical stop until the desired activation position is reached
- Tighten the lock grain

Should an opening direction reversion is required, the position of the stoppers must be inverted.

WIRE DIAGRAM

FIG.15

This figure shows an installation example of road barrier with its main accessories.

KEY

- 1 DA.24V control unit
- 2 Receiver photocell
- 3 Transmitter photocell
- 4 Emergency batteries that can be installed inside the container of the control unit
- 5 EVA:LAMP flashing light card
- 6 SC.RES pneumatic safety edge
- 7 SC.E circuit of interface SC.RES/DA:24V

To install and connect the various accessories, see related instructions.

WARNING

The RC product insurance policy, which covers any injuries or damages to objects caused by manufacturing defects, requires the use of Benincà's original accessories.

SAFETY MEASURES

- Do not stand within the gate movement area.
- Children must not play with controls and near the gate.
- In the event of malfunctions, do not attempt to repair the failure but contact the specialised personnel.

MANUAL AND EMERGENCY MANOEUVRE

Should a power failure occur or in the event of faults in the system, the beam can be released and moved by hand:

- Introduce the customized key in the release lever and turn it clockwise.
- Turn the release lever clockwise until the beam is released and it can be opened and closed by hand.
- To reset the automatic operation, turn the lever anti-clockwise until the beam is released. Reset the initial position.

MAINTENANCE

- Every month check the good operation of the emergency manual release.
- It is mandatory not to carry out extraordinary maintenance or repairs as accidents may be caused. These operations must be carried out by qualified personnel only.
- The operator is maintenance free but it is necessary to check periodically if the safety devices and the other components of the automation system work properly. Wear and tear of some components could cause dangers.

WASTE DISPOSAL

If the product must be dismantled, it must be disposed according to regulations in force regarding the differentiated waste disposal and the recycling of components (metals, plastics, electric cables, etc..). For this operation it is advisable to call your installer or a specialised company.

WARNING

All Benincá products are covered by insurance policy for any possible damages to objects and persons caused by construction faults under condition that the entire system be marked CE and only Benincá parts be used.

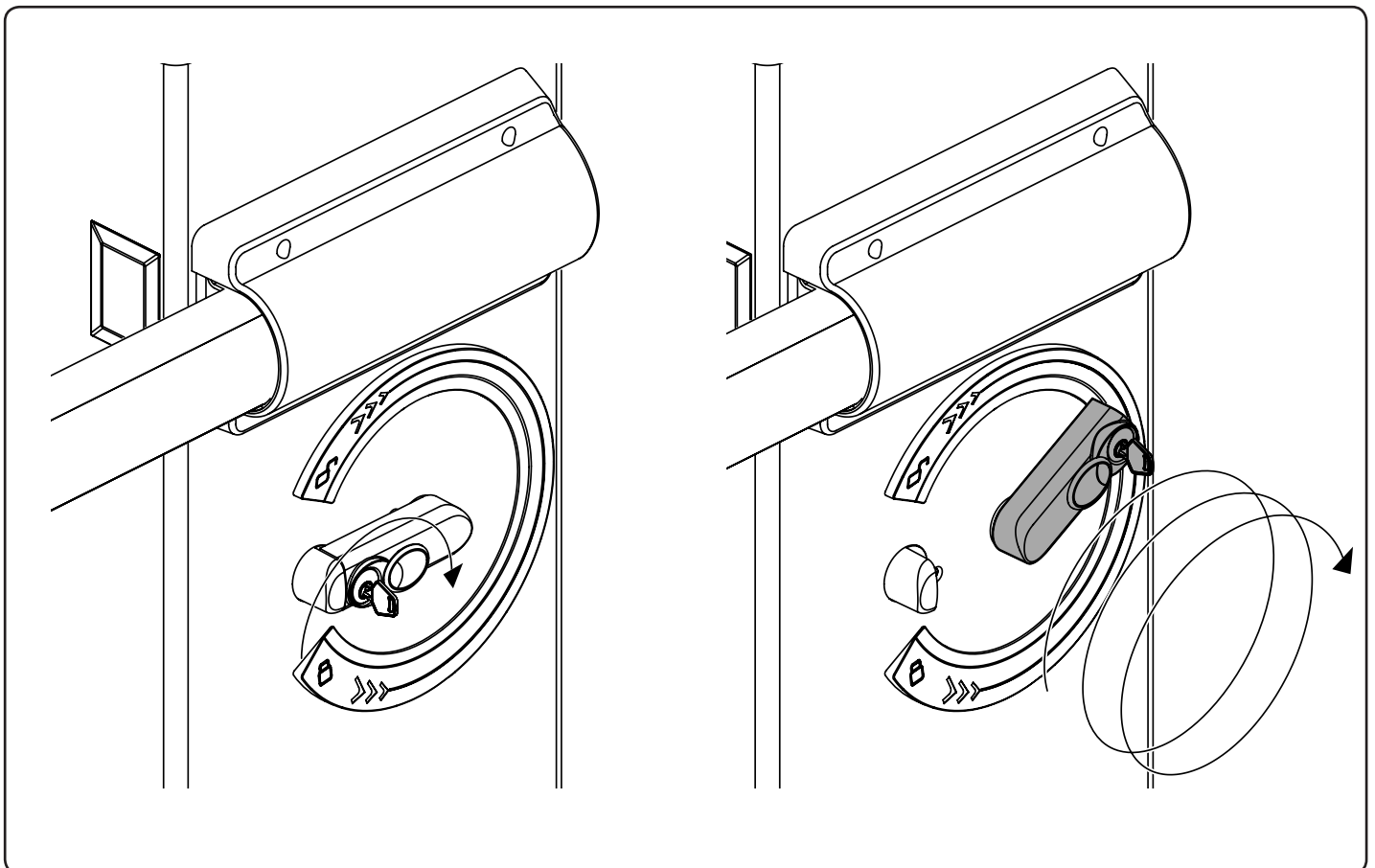

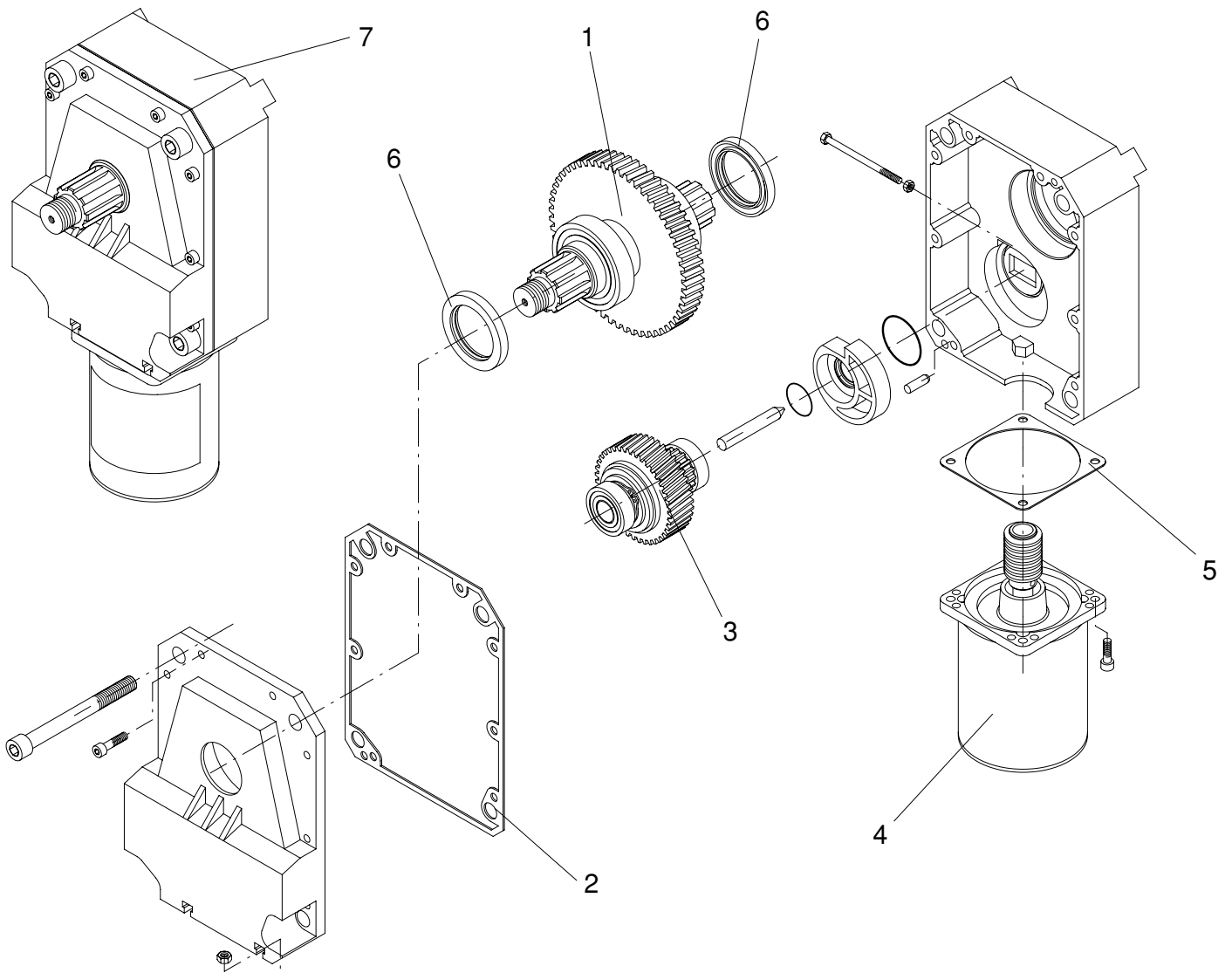

Ref.	EVA5 Code	Note
1	9686110	
2	9686112	
3	9686111	
4	9686107	
5	9686109	
6	9686555	
7	9686247	

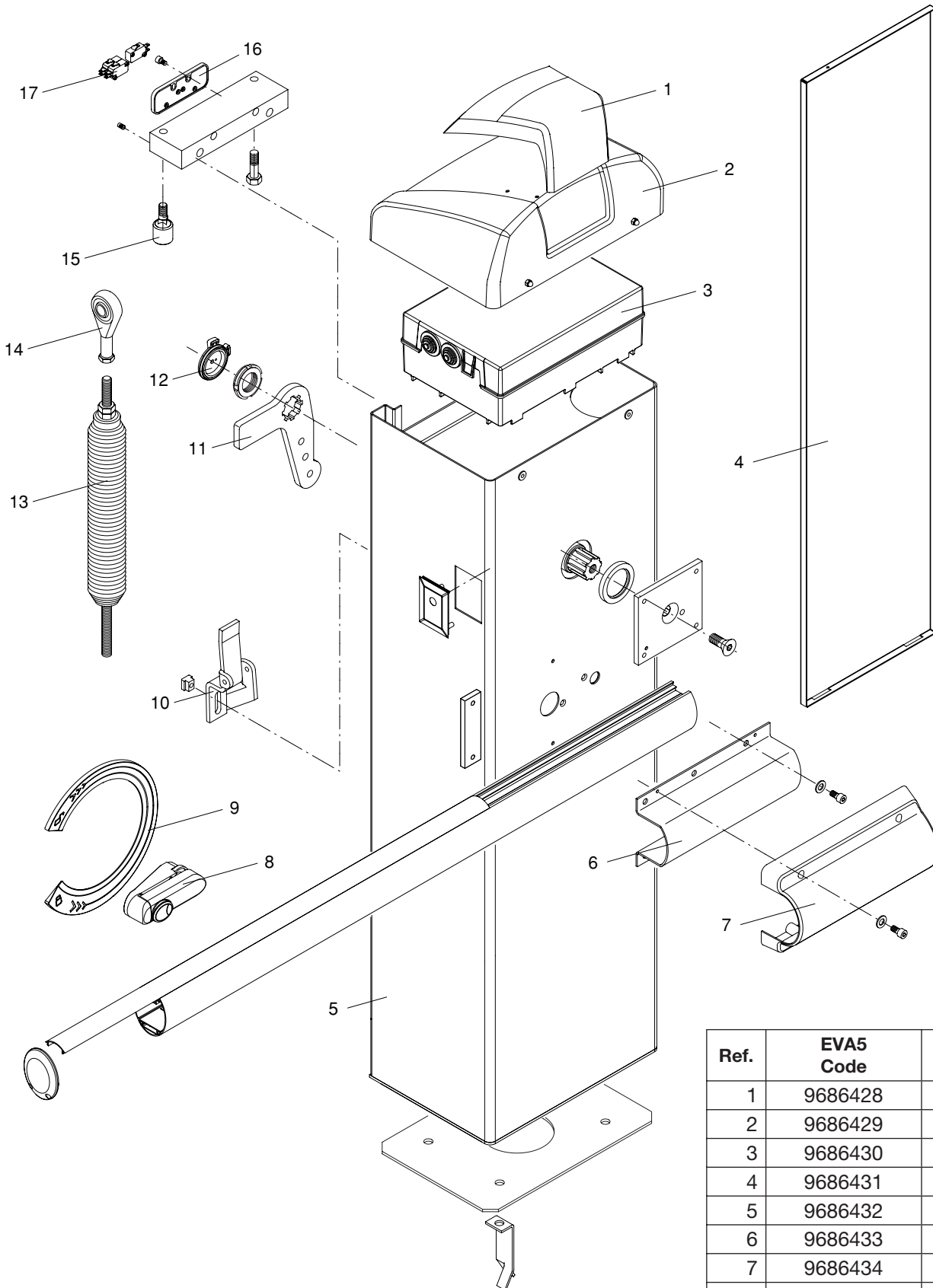

Ref.	EVA5 Code	Note
1	9686428	
2	9686429	
3	9686430	
4	9686431	
5	9686432	
6	9686433	
7	9686434	
8	9686435	
9	9686436	
10	9686190	
11	9686248	
12	9686160	
13	9686437	
14	9686666	
15	9686185	
16	9686438	
17	9686120	

BENINCA[®]

AUTOMATISMI BENINCÀ SpA - Via Capitello, 45 - 36066 Sandrigo (VI) - Tel. 0444 751030 r.a. - Fax 0444 759728
